

142207, . , RU.0001.11 26 » 29.03.2010 . , 17; .(4967) 76 18 89

CN.M 26. 00255

31

2011

SANLI, GRYPHON

TS50QT-4, TS50QT-8

-

STING-4 (TS50QT-4), COMETA (TS50QT-8)

L1

8711 10

VIN

LT8TSTBD?... (TS50QT-4),
LT8TSTBH?... (TS50QT-8)

« », 352080,

, 161,

SANLI ENGINE CO., LTD.
Meiling Industrial District, Qingyang Jinjiang, Fujian
Province, 362200, P.R. China

2,

/

2×1 /

N. 26. 00255

		2	
		STING-4 (TS50QT-4)	COMETA (TS50QT-8)
-		1650	1680
-		690	638
-		980	1010
		1220	1180
	-	80	80
		230	230
-		89	85
-		141	145
	(,)	AIQIKE, 139QMB,	-
-		1,	
-	, ³	49,6	
-		10,0	
		2,7 (7500)	
(1/)		3,7 (6500)	
	, (1/)		

POCC CN.MT26.E00255

		, 1		-
(,)		Zhejiang Liding Carburettor Co., Ltd., PE 187		
(,)		Zhejiang Hengbo Air Filter Co., Ltd.,		-
(,)		DI,		
(,)		SANILI, LH		
(,)		SANILI, LD.ATTC,		
(,)		Zhuzhou Torch Ignition Plug Co., Ltd.,		
		TORCH: A7RC		-
(,)		SANILI, SL07,		
(,)		SANILI,		
(,)		SANILI,		
:		9,60		
-		6,80		
-	(,)	SANILI,	c	
-		11,05		
-				-
-				-
(,)				
:				
(,)				
-		MFY,HC50,		-
		; - MFY,HC50,		-
-	(,)			

SERTAUTO.RU

N. 26. 00255

	STING-4 (TS50QT-4)		COMETA (TS50QT-8)	
- ,	3,50-10	3,50-10	3.00-10	3.00-10
- ,	-	-	-	-
- ,	51	51	42	42
	J	J	J	J

SERTAUTO

SANILI, GRYPHON TS50QT-4, TS50QT-8

2
3 2 .

« »

..

..

31 2010

SERTAUTO.RU

P CN. 26. 00255

1 « »

1	2	3
92/61 3-02,	MINISTERIO DE INDUSTRIA, TURISMO Y COMERCIO, SPAIN RDW VEHICLE TECHNOLOGY DIVISION THE NETHERLANDS	IA-E9-021200 IA-E9-021269 4* 92/61*0188*00 (TS50QT-4) 4*92/61*0189*00 (TS50QT-8)
(97/24/8, 92/61 10-02) -	RDW VEHICLE TECHNOLOGY DIVISION THE NETHERLANDS	4*92/61*0188*00 (TS50QT-4) 4*92/61*0189*00 (TS50QT-8)
(97/24/2, 92/61 37-03)		
(97/24/5, 92/61 47-00)	- “ -	- “ -
92/61 50-00	- “ -	E4-50R-0013540 E4-50R-0012972 4* 92/61*0188*00 (TS50QT-4) 4*92/61*0189*00 (TS50QT-8)

P CN. 26. 00255

1	2	3
(97/24/2, 92/61 56-01)	RDW VEHICLE TECHNOLOGY DIVISION THE NETHERLANDS	4*92/61*0188*00 (TS50QT-4) 4*92/61*0189*00 (TS50QT-8)
(93/29, 92/61 60-00)		
(93/33, 92/61 62-00)	- “ -	- “ -
(97/24/9, 92/61 63-01)	- “ -	- “ -
(93/92, 92/61 74-01) -	- “ -	- “ -
(97/24/1, 92/61 75-00)	- “ -	- “ -
(93/14, 92/61 78-02)	- “ -	- “ -
(97/24/4, 92/61 81-00)	- “ -	- “ -
(97/24/2, 92/61 112-00) -	- “ -	- “ -
(93/34, 92/61 51980, 37.001.269 .5)	- “ -	- “ -

« »

_____ . .

_____ . .

2 « »

1.

50460-92

2.

3.

(VIN):

3.1

3.2

4.

1	2	3	4	5	6	7	8	9	10	11	12	13	14	15	16	17
L		8		S	T	B	?	?	?	?	?	?	?	?	?	?

. 1÷3:

SANLI ENGINE CO., LTD. P.R. China

. 4÷7:

TSTB- (TS50QT)

. 8:

: D - TS50QT-4, H - TS50QT-8

. 9:

: 0 9

. 10:

: - 2010 .; - 2011 .

. 11÷17:

P CN. 26. 00255
3 «

»

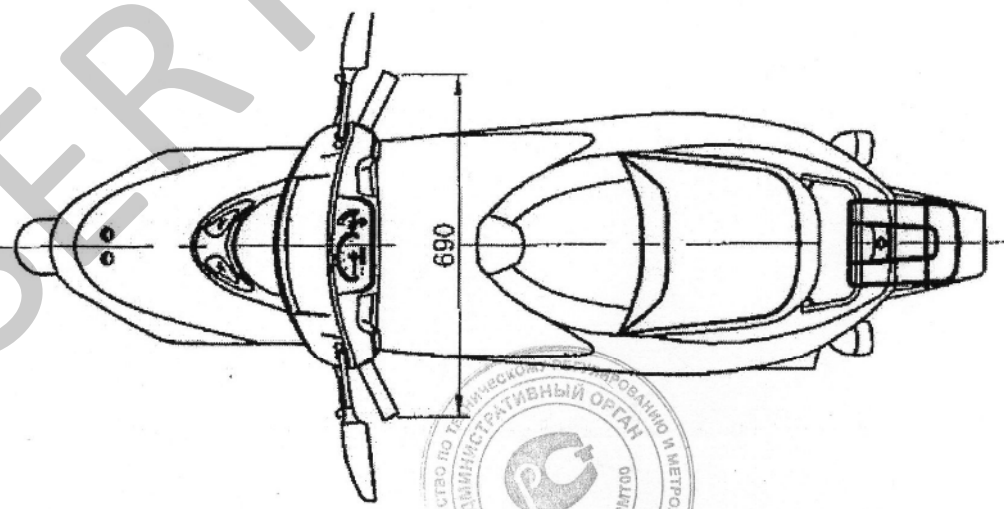
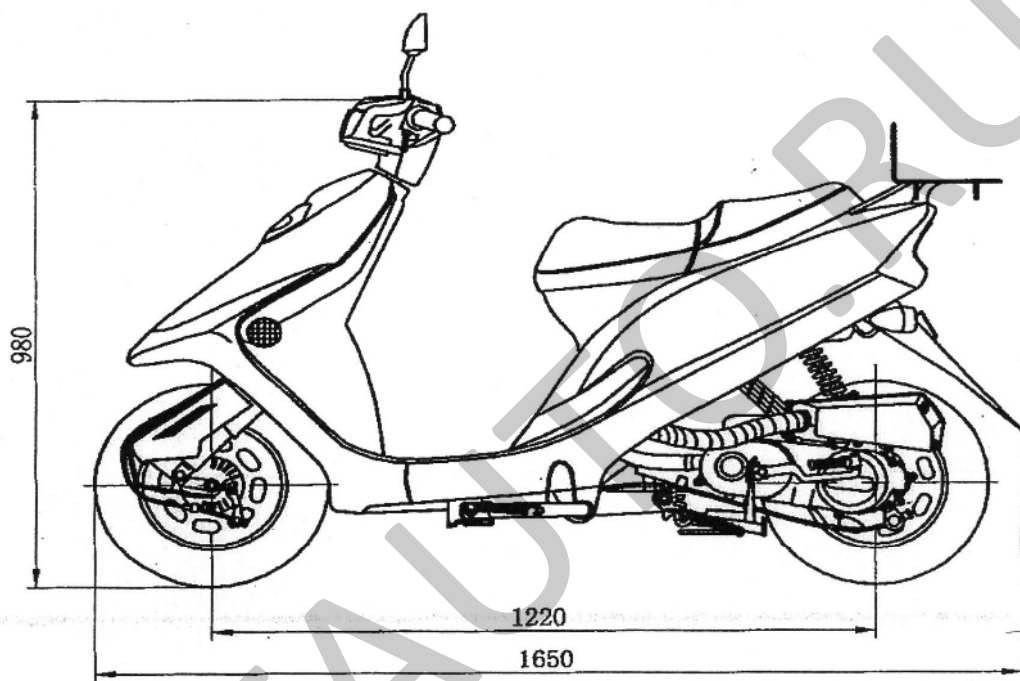

TS50QT-4

